



## DCR 85 CMOS Imager Code Reader



© 2017

Leuze electronic GmbH & Co. KG

In der Braike 1

D-73277 Owen / Germany

Phone: +49 7021 573-0

Fax: +49 7021 573-199

<http://www.leuze.com>

<b>1</b>	<b>About this document .....</b>	<b>5</b>
1.1	Used symbols and signal words .....	5
<b>2</b>	<b>Safety .....</b>	<b>6</b>
2.1	Intended use .....	6
2.2	Foreseeable misuse .....	6
2.3	Competent persons .....	6
2.4	Disclaimer .....	7
<b>3</b>	<b>Device description .....</b>	<b>8</b>
3.1	Device overview .....	8
3.1.1	About the DCR 85 code reader .....	8
3.1.2	Stand-alone operation .....	8
3.2	Performance characteristics .....	8
3.3	Device construction .....	9
3.4	Connection technology .....	9
3.5	Display elements .....	9
<b>4</b>	<b>Mounting .....</b>	<b>10</b>
4.1	Selecting a mounting location .....	10
<b>5</b>	<b>Electrical connection .....</b>	<b>11</b>
5.1	Voltage supply .....	11
5.2	Pin assignment .....	11
5.3	Switching input / switching output .....	11
5.3.1	Switching input .....	12
5.3.2	Switching output .....	12
5.4	PC or terminal connection .....	13
5.5	Cable lengths and shielding .....	13
<b>6</b>	<b>Configuration and diagnostics software - Sensor Studio .....</b>	<b>14</b>
6.1	System requirements .....	14
6.2	Installing Sensor Studio configuration software .....	15
6.2.1	Downloading configuration software .....	15
6.2.2	Installing the Sensor Studio FDT frame .....	15
6.2.3	Install the communication DTM and device DTM .....	15
6.2.4	Connecting device to PC .....	15
6.3	Starting the Sensor Studio configuration software .....	16
6.4	Exiting Sensor Studio .....	17
6.5	Configuration parameters .....	17
6.5.1	General tab .....	18
6.5.2	Decode tab .....	19
6.5.3	Host interface tab .....	20
6.5.4	Diagnosis / Terminal .....	20
6.5.5	Diagnosis / Image Viewer .....	21
<b>7</b>	<b>Starting up the device - Configuration .....</b>	<b>22</b>
7.1	Measures to be performed prior to the initial commissioning .....	22
7.2	Starting the device .....	22
7.2.1	Interface .....	22
7.2.2	Online commands .....	22
7.2.3	Problems .....	22
7.3	Setting the communication parameters .....	22

<b>8</b>	<b>Online commands .....</b>	<b>23</b>
8.1	Overview of commands and parameters .....	23
8.2	General online commands .....	24
8.3	Text commands .....	25
<b>9</b>	<b>Care, maintenance and disposal .....</b>	<b>34</b>
9.1	Cleaning .....	34
9.2	Servicing .....	34
9.3	Disposing .....	34
<b>10</b>	<b>Service and support .....</b>	<b>35</b>
10.1	What to do should servicing be required? .....	35
<b>11</b>	<b>Technical data .....</b>	<b>36</b>
11.1	General specifications .....	36
11.2	Reading fields .....	37
11.3	Dimensioned drawings .....	39
<b>12</b>	<b>Order guide and accessories .....</b>	<b>40</b>
12.1	Type overview .....	40
12.2	Accessories .....	40
<b>13</b>	<b>EC Declaration of Conformity .....</b>	<b>41</b>
<b>14</b>	<b>Appendix .....</b>	<b>42</b>
14.1	Bar code samples .....	42
14.2	Configuration via configuration codes .....	43



# 1 About this document

## 1.1 Used symbols and signal words

Tab. 1.1: Warning symbols and signal words

	Symbol indicating dangers to persons
NOTE	Signal word for property damage Indicates dangers that may result in property damage if the measures for danger avoidance are not followed.

Tab. 1.2: Other symbols

	Symbol for tips Text passages with this symbol provide you with further information.
	Symbols for action steps Text passages with this symbol instruct you to perform actions.
	Symbol for action results Text passages with this symbol describe the result of the preceding action.

Tab. 1.3: Terms and abbreviations

BCL	Bar code reader
CMOS	Semiconductor process for implementing integrated circuits (Complementary Metal-Oxide-Semiconductor)
DCR	Image-based code reader (Dual Code Reader)
DTM	Software device manager (Device Type Manager)
EMC	Electromagnetic compatibility
EN	European standard
FDT	Software frame for management of device managers (DTM) (Field Device Tool)
FE	Functional earth
GUI	Graphical user interface
HID	Device class for input devices with which users directly interact (Human Interface Device)
IO or I/O	Input/Output
LED	LED (Light Emitting Diode)
PLC	Programmable Logic Control (corresponds to Programmable Logic Controller (PLC))

## 2 Safety

This code reader was developed, manufactured and tested in accordance with the applicable safety standards. It corresponds to the state of the art.



### 2.1 Intended use

The DCR 85 code reader is designed as a stationary scanner with integrated decoder for all common 1D and 2D codes used for automatic object detection.

#### Areas of application

The DCR 85 code reader is intended especially for the following areas of application:

- In automatic analyzers
- For space-critical code reading tasks
- For installation in a housing or beneath covers

 <b>CAUTION</b>	
	<p><b>Observe intended use!</b></p> <p>The protection of personnel and the device cannot be guaranteed if the device is operated in a manner not complying with its intended use.</p> <ul style="list-style-type: none"> <li>↳ Only operate the device in accordance with its intended use.</li> <li>↳ Leuze electronic GmbH + Co. KG is not liable for damages caused by improper use.</li> <li>↳ Read these operating instructions before commissioning the device. Knowledge of the operating instructions is an element of proper use.</li> </ul>
<b>NOTICE</b>	
	<p><b>Comply with conditions and regulations!</b></p> <ul style="list-style-type: none"> <li>↳ Observe the locally applicable legal regulations and the rules of the employer's liability insurance association.</li> </ul>

### 2.2 Foreseeable misuse

Any use other than that defined under "Intended use" or which goes beyond that use is considered improper use.

In particular, use of the device is not permitted in the following cases:

- in rooms with explosive atmospheres
- in circuits which are relevant to safety
- for medical purposes

<b>NOTICE</b>	
	<p><b>Do not modify or otherwise interfere with the device!</b></p> <ul style="list-style-type: none"> <li>↳ Do not carry out modifications or otherwise interfere with the device. The device must not be tampered with and must not be changed in any way.</li> <li>↳ The device must not be opened. There are no user-serviceable parts inside.</li> <li>↳ Repairs must only be performed by Leuze electronic GmbH + Co. KG.</li> </ul>

### 2.3 Competent persons

Connection, mounting, commissioning and adjustment of the device must only be carried out by competent persons.

Prerequisites for competent persons:

- They have a suitable technical education.
- They are familiar with the rules and regulations for occupational safety and safety at work.
- They are familiar with the technical description of the device.
- They have been instructed by the responsible person on the mounting and operation of the device.

**Certified electricians**

Electrical work must be carried out by a certified electrician.

Due to their technical training, knowledge and experience as well as their familiarity with relevant standards and regulations, certified electricians are able to perform work on electrical systems and independently detect possible dangers.

In Germany, certified electricians must fulfill the requirements of accident-prevention regulations BGV A3 (e.g. electrician foreman). In other countries, there are respective regulations that must be observed.

**2.4 Disclaimer**

Leuze electronic GmbH + Co. KG is not liable in the following cases:

- The device is not being used properly.
- Reasonably foreseeable misuse is not taken into account.
- Mounting and electrical connection are not properly performed.
- Changes (e.g., constructional) are made to the device.

### **3 Device description**

#### **3.1 Device overview**

##### **3.1.1 About the DCR 85 code reader**

The code reader is based on a CMOS imager with integrated decoder for all of the most popular 1D and 2D codes such as DataMatrix, Aztec, QR Code, 2/5 Interleaved, Code 39, Code 128, UPC/EAN etc.

The many possible configurations of the device allow it to be adapted to a multitude of reading tasks. Due to the small dimensions of the unit and the large reading field, the scan engine can also be used in highly constrained spaces.

Information on technical data and characteristics: see chapter 11 "Technical data".

##### **3.1.2 Stand-alone operation**

The code reader is operated as a "stand-alone" single device. It is equipped with a 6-wire cable with open ends for the electrical connection of the supply voltage, the interface, the trigger input and the switching output.

#### **3.2 Performance characteristics**

- High-performance, miniature CMOS Imager with front beam exit
- Compact design for simple integration, even in constrained spaces
- Reading of extremely small high-density codes and recording of standard codes in a large reading area using a special optical system
- Reading of shiny surfaces using a gloss reduction process
- Excellent decoding characteristics
- Clearly visible alignment LED
- RS 232 interface, one triggering input, one switching output

### 3.3 Device construction

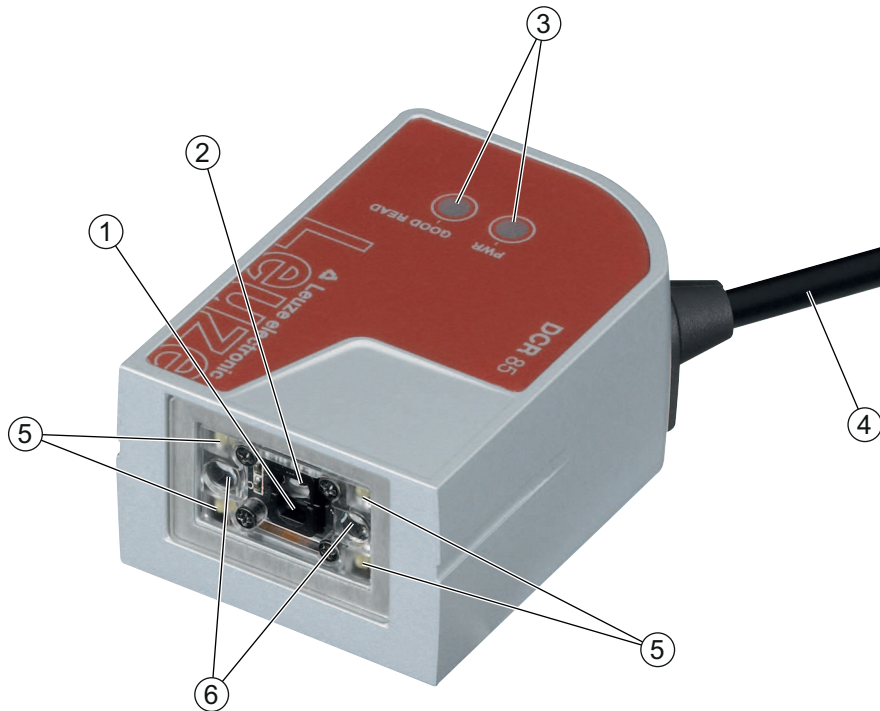

- 1 High resolution reading field lens
- 2 Wide-range reading field lens
- 3 LED indicators
- 4 Connection cable
- 5 LEDs for illumination (red light)
- 6 Alignment LEDs (blue light)

Fig. 3.1: Device construction of the DCR 85

### 3.4 Connection technology

- Connection cable, 6-wire with open cable end
- Cable (approx. 0.15 m) with M12 connector, 8-pin

### 3.5 Display elements

Located on device top are two LEDs that indicates the readiness for operation and the read status.

Tab. 3.1: LED indicators

LED	State	Description
PWR	ON (continuous light)	Voltage supply OK
GOOD READ	ON (continuous light)	Reading successful

## 4 Mounting

You can fasten the code reader at the M2.5 mounting threads.

### 4.1 Selecting a mounting location

<b>NOTICE</b>	
	The size of the code module influences the maximum reading distance and the width of the reading field. Therefore, when selecting a mounting location and/or the code label, take into account the different reading characteristics of the scanner with various code modules.

<b>NOTICE</b>	
	<p><b>Observe when choosing the mounting location!</b></p> <ul style="list-style-type: none"> <li>↳ Maintaining the required environmental conditions (temperature, humidity).</li> <li>↳ Possible soiling of the reading window due to liquids, abrasion by boxes, or packaging material residues.</li> <li>↳ Lowest possible chance of damage to the scanner by mechanical collision or jammed parts.</li> <li>↳ Possible extraneous light influence (no direct sunlight).</li> </ul>

In order to select the right mounting location, several factors must be considered:

- Size, orientation, and position tolerance of the bar codes or Data Matrix codes on the objects to be scanned.
- The reading field of the code reader in relation to the code module width.
- The resulting minimum and maximum reading distance from the respective reading field (see chapter 11.2 "Reading fields").
- Alignment of the code reader for avoiding reflections.
- Distance between code reader and host system with respect to the interface.

The best read results are obtained when

- the reading distance lies in the middle area of the reading field.
- there is no direct sunlight and extraneous light is avoided.
- the bar code labels are of good print quality and have good contrast ratios.
- you do not use high-gloss labels.
- the bar code or the Data Matrix code is moved past the reading window with an angle of rotation of 10° to 15°.
- the red light beam is narrowed down for its respective reading task in order to avoid reflections on shiny components.

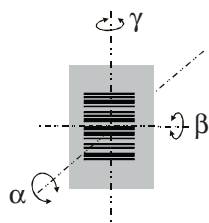

<b>NOTICE</b>	
	The front beam exit of the scan engine is almost vertical to the optics. The code label must be rotated by > 10° to avoid a total reflection of the red light beam in the case of glossy labels.



- $\alpha$  Azimuth angle
  - $\beta$  Angle of inclination
  - $\gamma$  Angle of rotation
- Recommended angle of rotation:  $\gamma > 10^\circ$

Fig. 4.1: Definition of the reading angles

## 5 Electrical connection

	<b>CAUTION</b>
	<p><b>Safety notices</b></p> <ul style="list-style-type: none"> <li>↳ Before connecting the device, be sure that the supply voltage agrees with the value printed on the name plate.</li> <li>↳ Connection of the device and maintenance work while under voltage must only be carried out by a qualified electrician.</li> <li>↳ The power supply unit for the generation of the supply voltage for the code reader and the corresponding connection units must have a secure electrical insulation according to IEC 60742 (PELV). For UL applications: only for use in class 2 circuits according to NEC.</li> <li>↳ If faults cannot be cleared, the device should be switched off and protected against accidental use.</li> </ul>

### 5.1 Voltage supply

The code reader is designed for connection to a 5 V supply voltage.

- +5 V DC (red)
- GND (violet)

An adapter circuit board with spring terminals, Molex plug connector and 9-pin SUB-D socket is available as an accessory (see chapter 12.2 "Accessories").

- With the adapter circuit board, the conductors of the connection cable can be contacted via the spring terminals and connected to the PC via the 9-pin SUB-D socket with an RS 232 interconnection cable.
- With the adapter circuit board, the voltage supply of 10 ... 30 V DC can be fed in via spring terminals or, alternatively, 5 V DC can be fed in via a micro USB connector.

### 5.2 Pin assignment

Tab. 5.1: Cable with open wire ends

Wire	Assignment	Description	
Red	+5V DC	Operating voltage 5V DC	IN
Violet	GND	Operating voltage 0V DC / reference ground	IN
Black	SW OUT	Switching output	OUT
Orange	SW IN	Switching input	IN
White	RS 232 RxD	RxD signal line of the RS 232 interface	IN
Green	RS 232 TxD	TxD signal line of the RS 232 interface	OUT

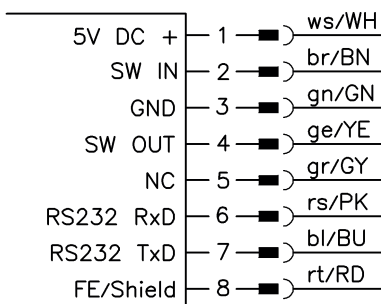

Fig. 5.1: Cable with M12 connector, 8-pin, A-coded

### 5.3 Switching input / switching output

The code reader is provided with a switching input and a switching output.

- The switching input is used to trigger code reading.
- The switching output signals successful code reading.

### 5.3.1 Switching input

By means of the SW IN switching input connection, you can trigger a read process in the standard setting (low = active) with the connection TRIGGER (orange) and GND (violet). We recommend wiring a 2.2 kΩ pull-up resistor as defined cable termination.

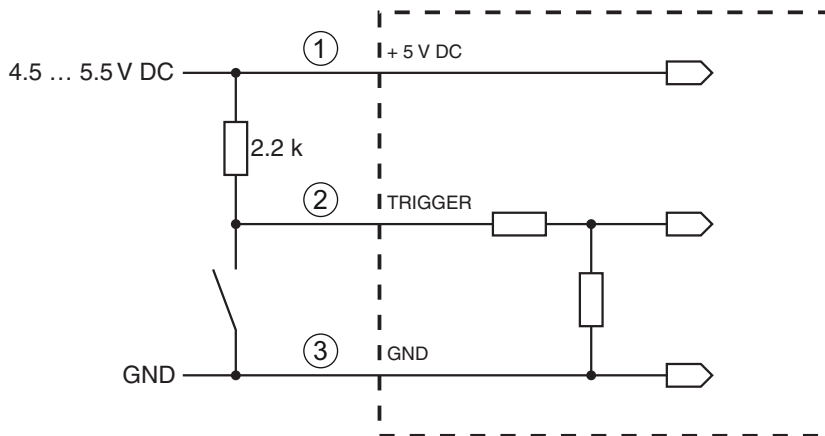

- 1 Red
  - 2 Orange
  - 3 Violet
- Connection version NPN: standard setting (low = active)

Fig. 5.2: Switching input for connection variant NPN (standard setting)

### 5.3.2 Switching output

The NPN switching output connection between switching output (black) and GND (violet) switches if a code is detected against GND.

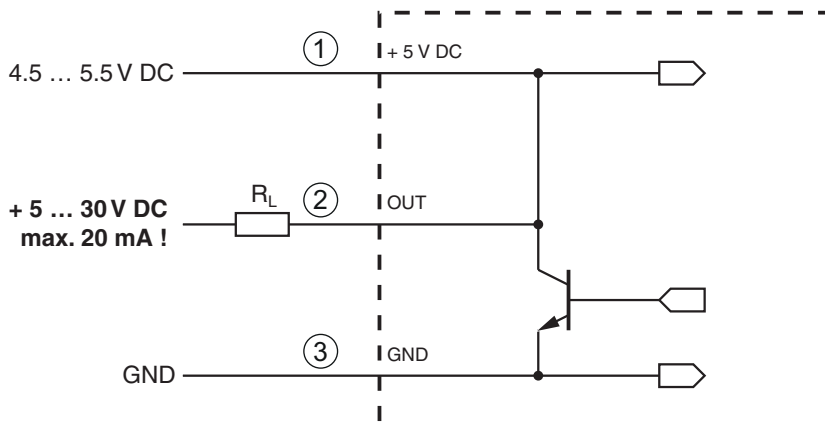

- 1 Red
- 2 Black
- 3 Violet

Fig. 5.3: Switching output

**NOTICE**

**Maximum loading of the switching output**

⚠ Do not load the switching output of the code reader with more than 20 mA at +5 ... 30 V DC!

### 5.4 PC or terminal connection

Via the serial interface, you can configure the code reader by means of a PC or terminal. For this, you need an RS 232 connection that establishes the RxD, TxD and GND connections between PC and code reader.

The RS 232 connection can be established in the following ways:

- Direct connection of the code reader connection wires to the PC or terminal via its own connector.
- Connection via an MA-CR adapter circuit board

To simplify the connection of the connection wires to the PC interface, an adapter circuit board (MA-CR) is available for implementing individual wire contacting to SUB-D, 9-pin (see chapter 12.2 "Accessories").

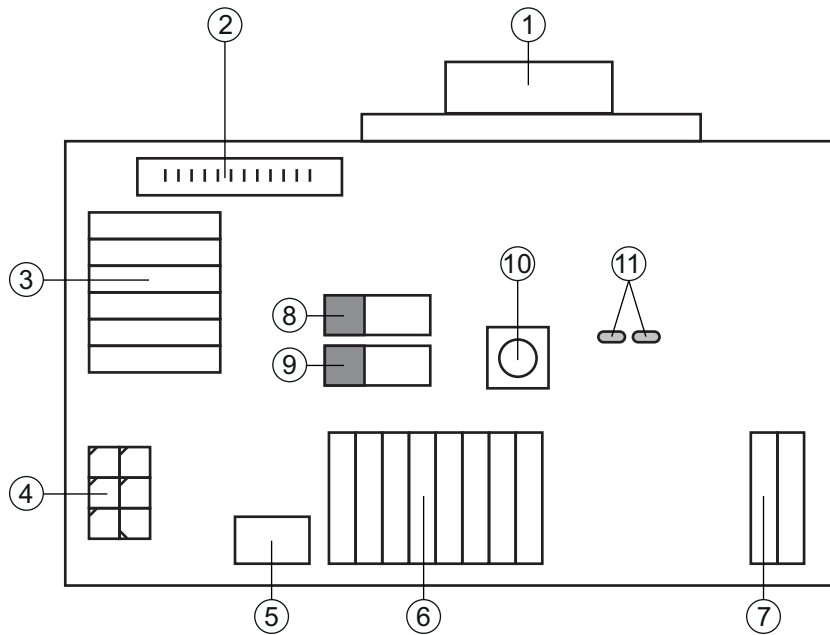

- 1 RS 232 connection
- 2 CR 50 or DCR 80 connection
- 3 CR 100, CR 55, DCR 85 connection
- 4 Molex Micro-Fit, 6-pin
- 5 USB connection
- 6 Connection to machine control, PLC, external voltage supply 5 VDC
- 7 External voltage supply 10 ... 30 VDC
- 8 SWIN DIP switch (level for trigger button; 5 V if the scanner high switching input is active, GND if the low input is active)
- 9 USB/PWR DIP switch (USB position if voltage is supplied via USB; PWR position if voltage is supplied via (7))
- 10 Trigger button
- 11 Status LEDs

Fig. 5.4: Connection options for MA-CR adapter circuit board

### 5.5 Cable lengths and shielding

The maximum cable length is 3 m.

Should a cable extension be necessary, make certain that the cables of the RS 232 interface are shielded.

## 6 Configuration and diagnostics software - Sensor Studio

The *Sensor Studio* configuration software provides a graphical user interface for the operation, configuration and diagnosis of the device via the RS 232 interface.

A device that is not connected to the PC can be configured offline.

Configurations can be saved and reopened as projects for transferring back to the device at a later time.

<b>NOTICE</b>	
	<p>Only use the <i>Sensor Studio</i> configuration software for products manufactured by Leuze electronic.</p> <p>The <i>Sensor Studio</i> configuration software is offered in the following languages: German, English, French, Italian and Spanish.</p> <p>The FDT frame application of the <i>Sensor Studio</i> supports all languages; all languages may not be supported in the device DTM (Device Type Manager).</p>

The *Sensor Studio* configuration software is designed according to the FDT/DTM concept:

- You make the individual configuration settings for the bar code reader in the Device Type Manager (DTM).
- The individual DTM configurations of a project can be called up via the frame application of the Field Device Tool (FDT).
- Communication DTM for code readers: *LeCommInterface*
- Device DTM for the DCR 85 code reader

Procedure for the installation of the software and hardware:

- ↪ Install the *Sensor Studio* configuration software on the PC.
- ↪ Install the communication and device DTM.  
Communication and device DTM are included in the *LeAnalysisCollectionSetup* installation package.
- ↪ Create DCR 85-DTM in the project tree of the *Sensor Studio* FDT frame.
- ↪ Connect code reader to PC (see chapter 5.4 "PC or terminal connection").

### 6.1 System requirements

To use the *Sensor Studio* configuration software, you need a PC or laptop with the following specifications:

Tab. 6.1: System requirements for *Sensor Studio* installation

Operating system	Windows XP or higher (32 bit, 64 bit) Windows Vista Windows 7 Windows 8
Computer	Processor type: 1 GHz or higher Serial COM interface CD-ROM drive Main memory (RAM): at least 64 MB Keyboard and mouse or touchpad
Graphics card	At least 1024 x 768 pixels
Required hard disk capacity for <i>Sensor Studio</i> and communication DTM	35 MB

<b>NOTICE</b>	
	Administrator privileges on the PC are necessary for installing <i>Sensor Studio</i> .

## 6.2 Installing Sensor Studio configuration software

### NOTICE



The installation files of the *Sensor Studio* configuration software must be downloaded from the Internet at **www.leuze.com**.

For subsequent updates, you can find the most recent version of the *Sensor Studio* installation software on the Internet at **www.leuze.com**.

### 6.2.1 Downloading configuration software

- ↪ Call up the Leuze home page: **www.leuze.com**
- ↪ Enter the type designation or part number of the device as the search term.
- ↪ The configuration software can be found on the product page for the device under the *Downloads* tab.

### 6.2.2 Installing the Sensor Studio FDT frame

### NOTICE



#### First install the software!

- ↪ Do not yet connect the device to the PC. First install the software.

### NOTICE



If FDT frame software is already installed on your PC, you do not need the *Sensor Studio* installation.

You can install the communication DTM and the device DTM in the existing FDT frame. Communication DTM and device DTM are included in the *LeAnalysisCollectionSetup* installation package.

- ↪ Start the PC.
- ↪ Download the configuration software from the Internet to the PC (see chapter 6.2.1 "Downloading configuration software").  
Unpack the installation package.
- ↪ Start the *SensorStudioSetup.exe* file.
- ↪ Follow the instructions on the screen.

The Installation Wizard installs the software and places a shortcut on the desktop ()

### 6.2.3 Install the communication DTM and device DTM

Prerequisites:

- ✓ An FDT frame is installed on the PC.
- ↪ Start the *LeAnalysisCollection.exe* file from the installation package and follow the instructions on the screen.

The installation wizard installs communication DTM and device DTM for DCR 85.

### 6.2.4 Connecting device to PC

The device is connected to the PC via the RS 232 interface.

- You need an RS 232 connection that establishes the RxD, TxD and GND connections between PC and device (see chapter 5.4 "PC or terminal connection").
- The 5 V DC voltage supply is to be fed in externally (see chapter 5.1 "Voltage supply").

**NOTICE**

 The MA-CR adapter circuit board with spring terminals and plug connector for connecting the device, as well as 9-pin SUB-D socket for connecting an RS 232 interconnection cable, is available as an accessory. An RS 232 interconnection cable to the PC is also available as an accessory (see chapter 12 "Order guide and accessories").

The adapter circuit board requires 10 V ... 30 V DC as external voltage supply, which can be fed in via spring terminals.

### 6.3 Starting the Sensor Studio configuration software

Prerequisites:

- The device has been mounted (see chapter 4 "Mounting") and connected (see chapter 5 "Electrical connection") correctly.
- The device is connected to the PC via the RS 232 interface (see chapter 6.2.4 "Connecting device to PC").
- The *Sensor Studio* configuration software is installed on the PC (see chapter 6.2 "Installing Sensor Studio configuration software").

➤ Start the *Sensor Studio* configuration software by double-clicking the *Sensor Studio* icon (). The **mode selection** of the **Project Wizard** is displayed.

➤ Select the **Device selection without communication connection (offline)** configuration mode and click on [Next].

The **Project Wizard** displays the **device selection** list of the configurable devices.

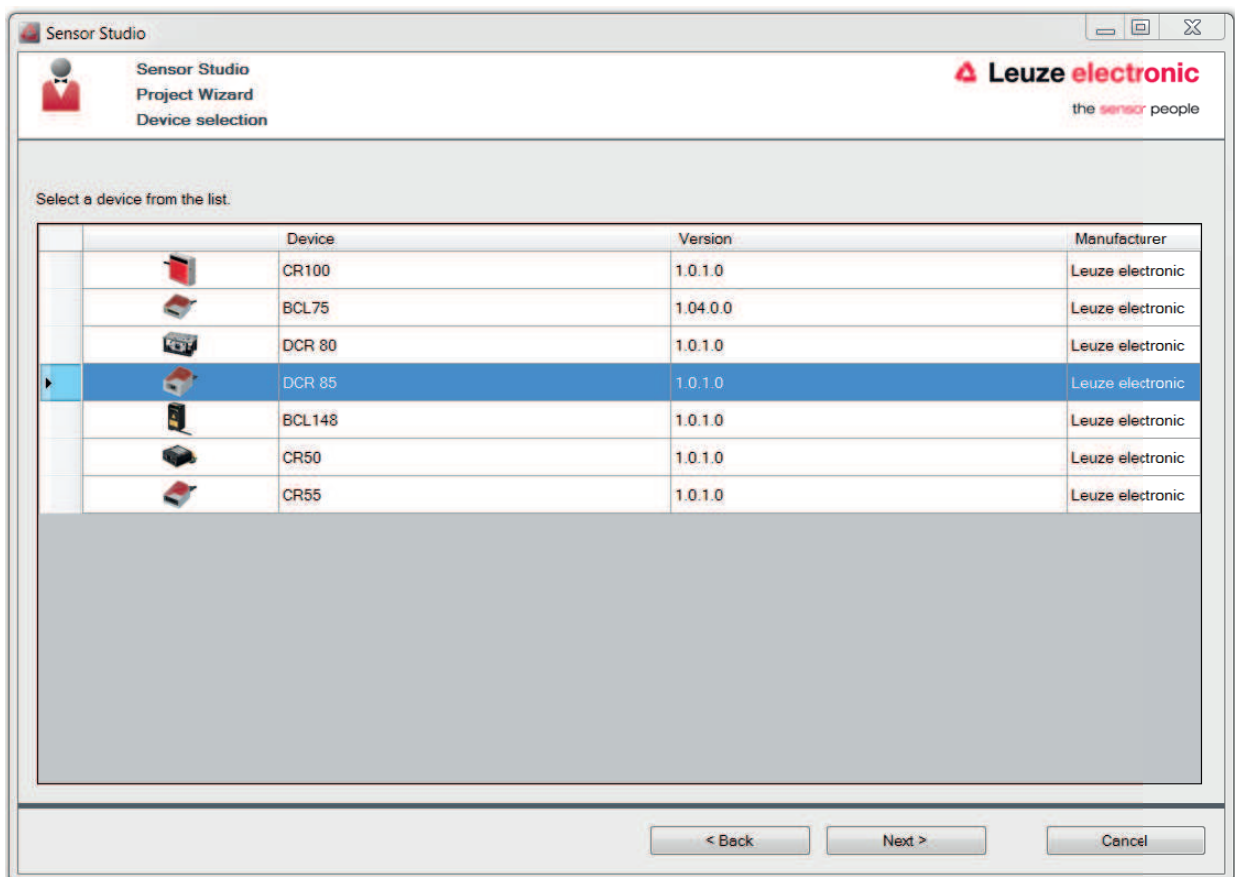

Fig. 6.1: Device selection for code reader CR 85

➤ Select **DCR 85** in the **device selection** and click on [Next]. The device manager (DTM) of the connected DCR 85 starts with the offline view for the *Sensor Studio* configuration project.

Establish the online connection to the connected DCR 85.

In the *Sensor Studio* FDT frame, click on the [Establish connection with device] button (▶).

In the *Sensor Studio* FDT frame, click on the [Upload parameters to device] button (⬆).

The current configuration data is displayed in the device manager (DTM).

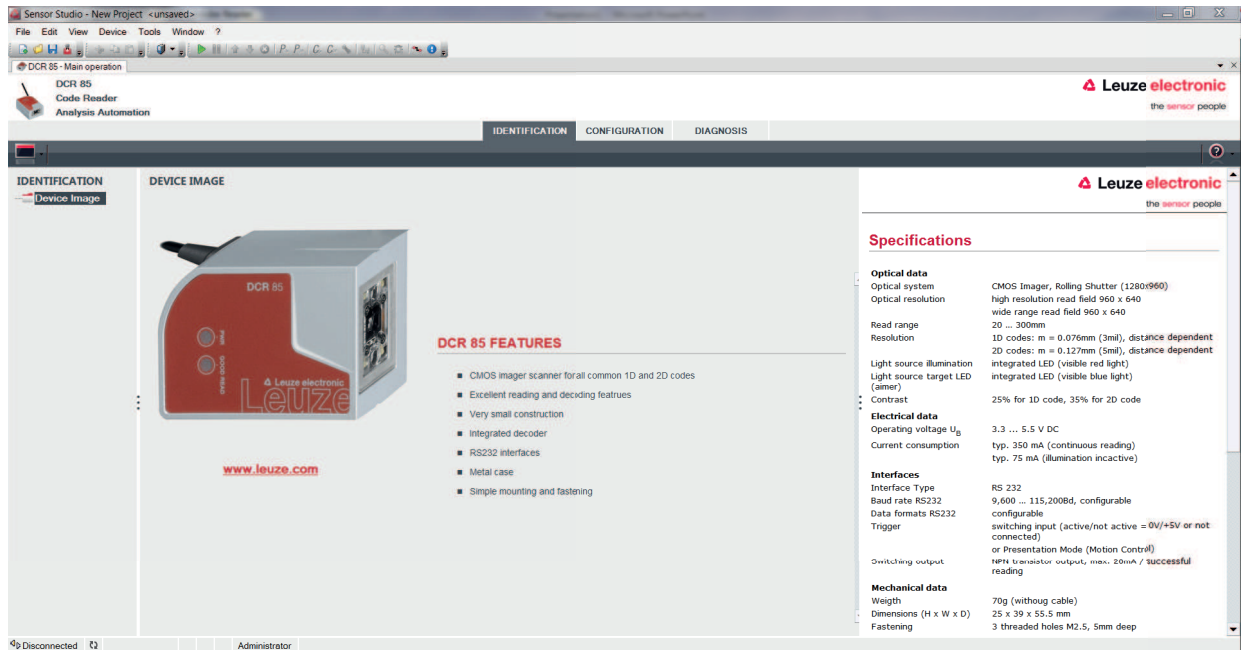

Fig. 6.2: Configuration project: Sensor Studio device manager (DTM) for DCR 85

The menus of the *Sensor Studio* device manager (DTM) can be used to change or read out the configuration of the connected device.

The user interface of the *Sensor Studio* device manager (DTM) is largely self-explanatory.

The online help system provides information on the menu items and adjustment parameters. Select the **Help** menu item in the menu [?] (🔍).

Transfer the modified configuration parameters to the device.

If a connection exists, click on the [Download parameters to device] button (⬇) on the task bar.

## 6.4 Exiting Sensor Studio

After completing the configuration settings, close the *Sensor Studio* configuration software.

Exit the program via **File > Exit**.

Save the configuration settings as a configuration project on the PC.

You can open the configuration project again at later time via **File > Open** or with the *Sensor Studio* **Project Wizard** (🔧).

## 6.5 Configuration parameters

In this chapter, you will find information and explanations on the configuration parameters of the device manager (DTM).

### NOTICE



This chapter does not include a complete description of the *Sensor Studio* configuration software.

Complete information on the FDT frame menu and on the functions in the device manager (DTM) can be found in the online help system.

The device manager (DTM) of the *Sensor Studio* configuration software offers the following configuration functions:

- *General (Control)*
- *Decode* (see chapter 6.5.2 "Decode tab")

- *Host Interface* (see chapter 6.5.3 "Host interface tab")
- *Diagnosis* (see chapter 6.5.4 "Diagnosis / Terminal")

**NOTICE**



The online help system displays information on the menu items and configuration parameters for each function. Select the **Help** menu item in the menu [?].

6.5.1 General tab

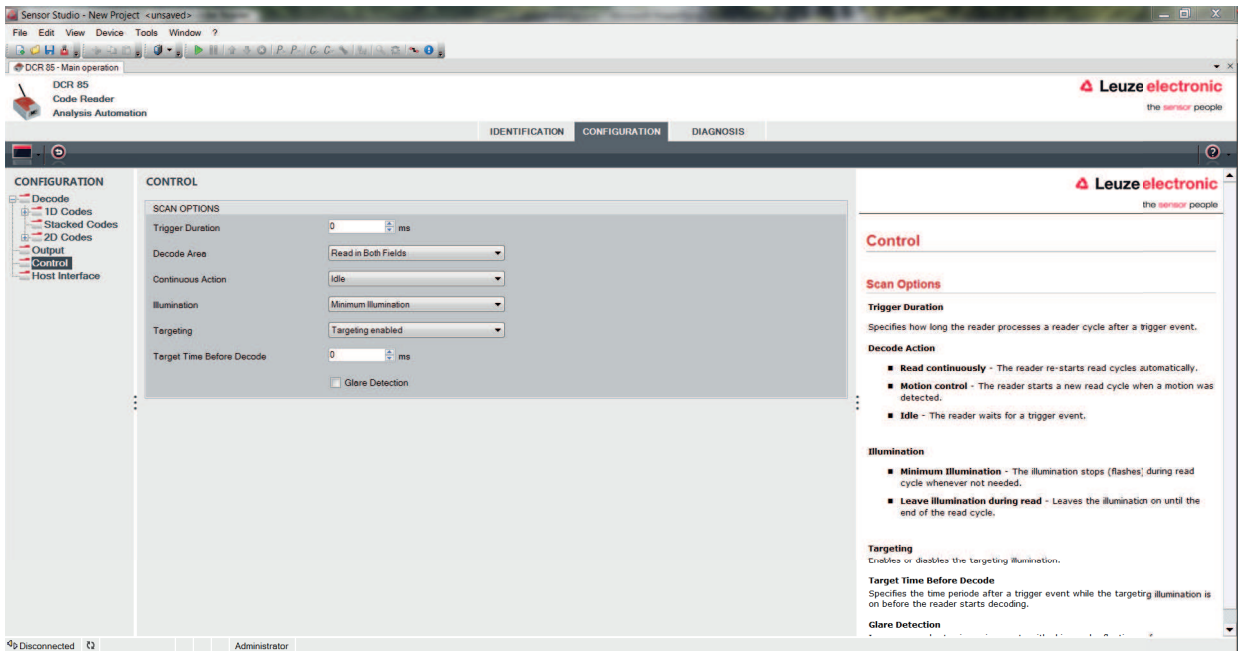

Fig. 6.3: General tab

Trigger duration (Trigger Duration)	Set the time, for which a read cycle remains active after a trigger event.  Example: trigger duration = 3000 ms means that the scanner tries to decode a code for a maximum of three seconds after a trigger event. The read cycle ends after successful decoding or after the time that has been preset here has elapsed.
Reading fields (Decode Area)	Selection of the reading field. The scan engine has two reading fields: <ul style="list-style-type: none"> <li>• High resolution reading field</li> <li>• Wide-range reading field</li> </ul>
Scan mode (Continuous Action)	Selection of the reading behavior: <ul style="list-style-type: none"> <li>• Read when triggered</li> <li>• Presentation mode</li> <li>• Duration reading</li> </ul>
LED illumination (Illumination)	Set the illumination time of the LEDs after successful reading.
Target illumination (Targeting)	Switch the blue alignment LEDs on and off.
Target illumination time setting (Target Time before Decode)	Setting of the time until which reading takes place after a trigger event. The blue alignment LEDs light up immediately when the trigger event occurs.

6.5.2 Decode tab

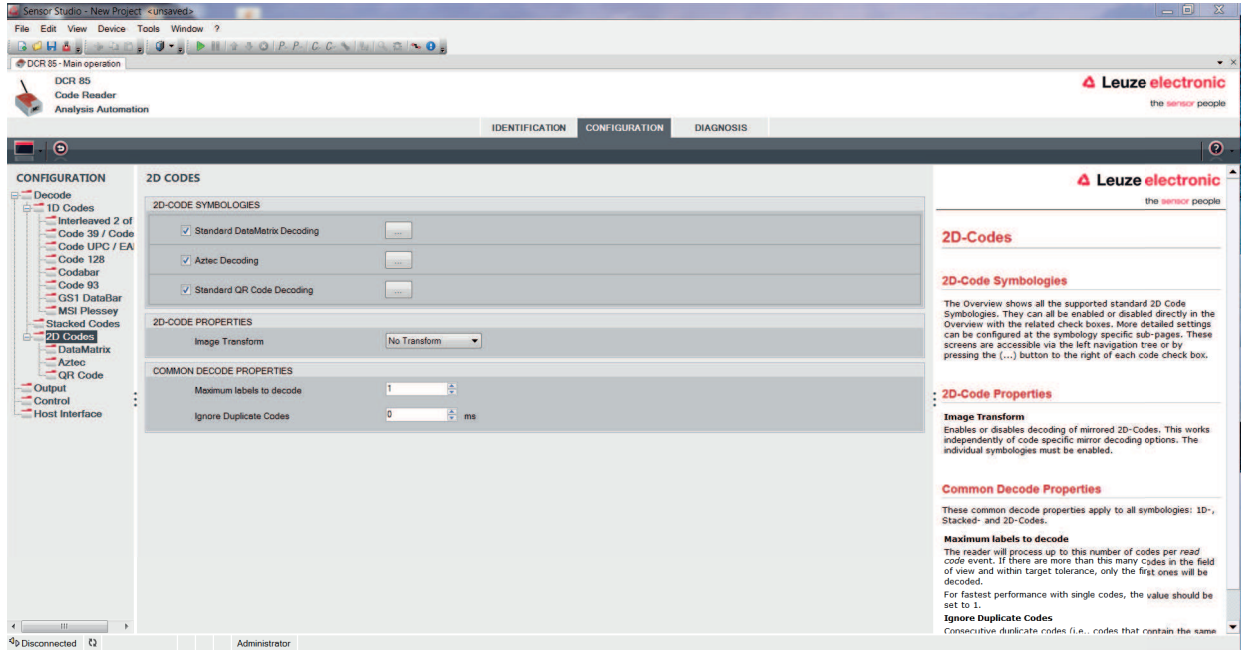

Fig. 6.4: Decode tab

<p>Code table (DECODE)</p>	<p>Here, the codes which are to be decoded are set. We recommend enabling only the code types which are to actually be read with the corresponding element numbers. Codes which are not enabled are not decoded!</p>
<p>Properties (SYMBOLOGIES)</p>	<p>Use the ... button to the right of the given code to select the code-specific settings. Alternatively, the property settings can be selected directly via the navigation tree under the Decode button. The properties can be individually set for each <b>code type</b>.</p>

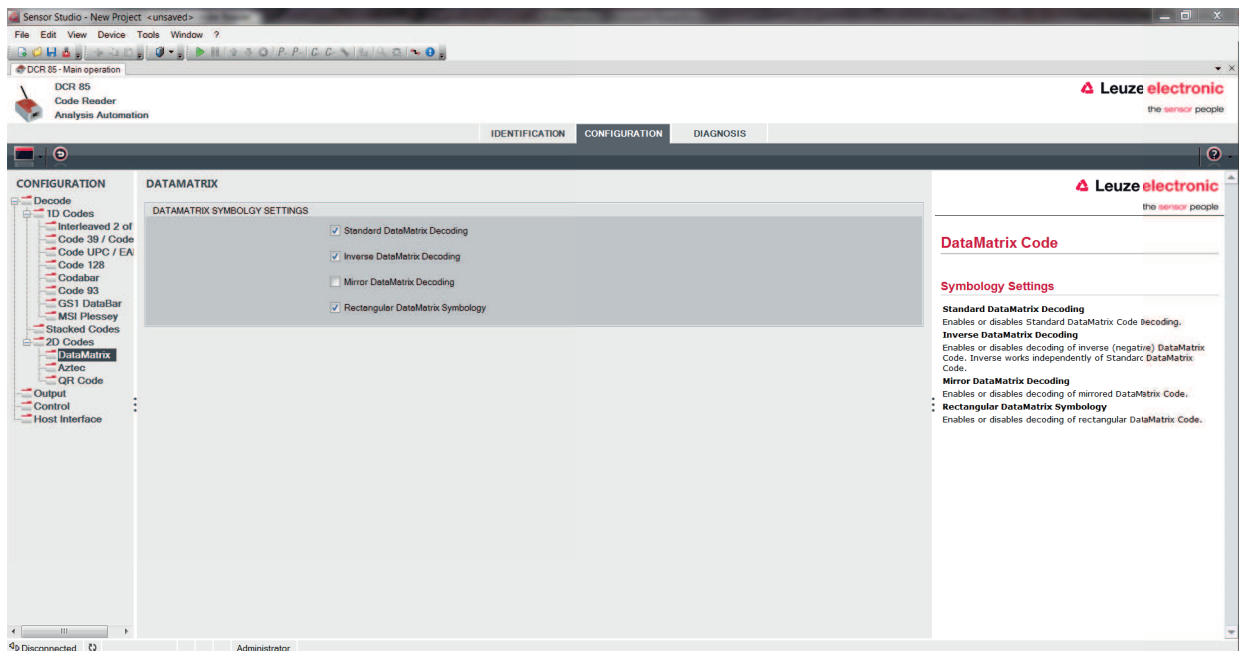

Fig. 6.5: Standard settings for the Properties window (SYMBOLOGY SETTINGS) – Decode tab

### 6.5.3 Host interface tab

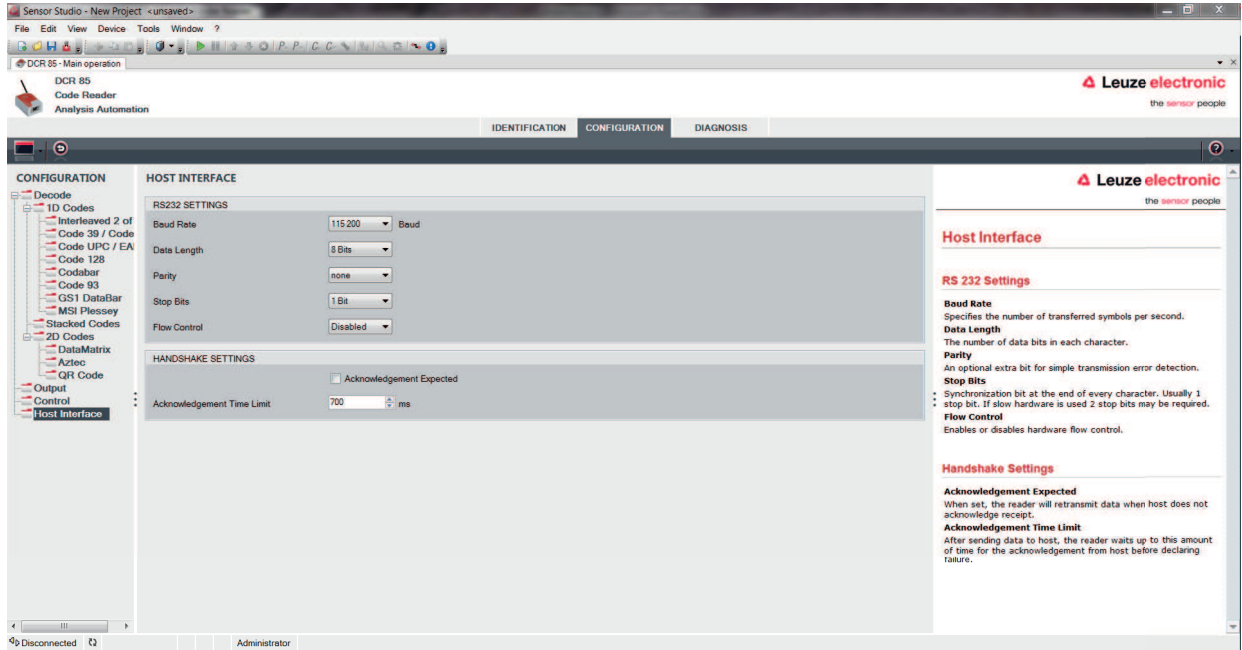

Fig. 6.6: Host interface tab

Select the desired baud rate, the stop bits, the data bits, the parity and various transmission modes here. The desired acknowledgment settings are also to be set in this selection window.

### 6.5.4 Diagnosis / Terminal

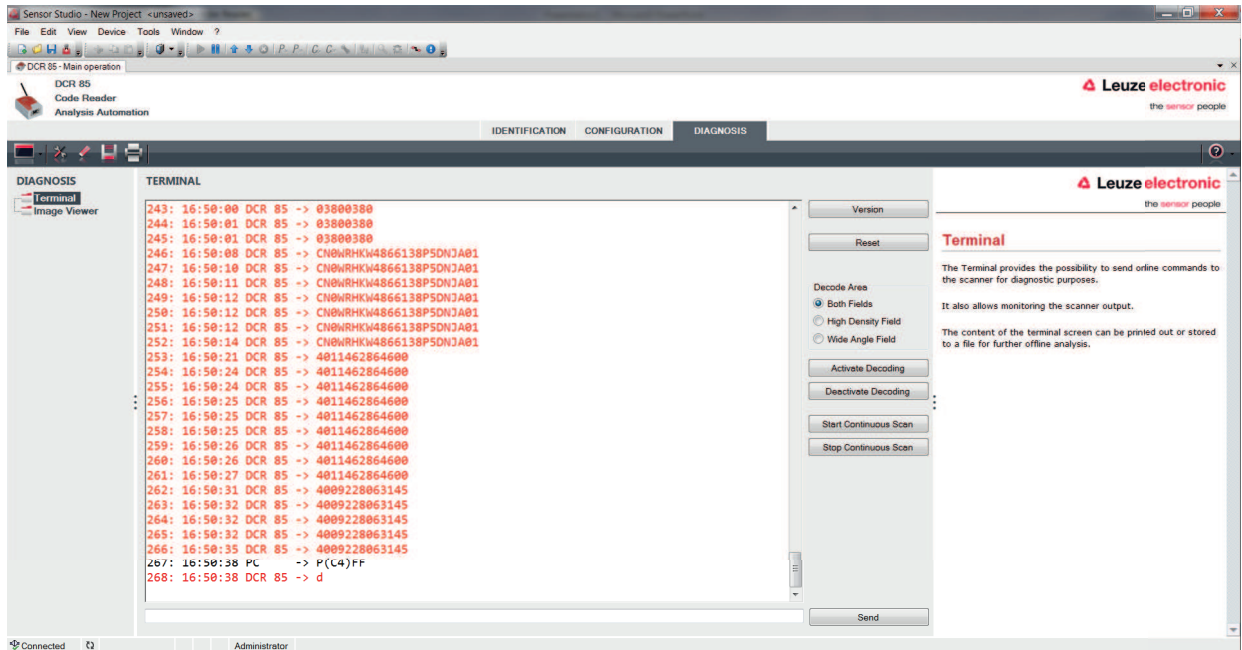

Fig. 6.7: Terminal

The Terminal tab provides the following functions:

- Send online commands to the code reader for diagnostic purposes.
- Visualize the code reader output.

The contents of the terminal display can be printed out or saved in a file for subsequent offline evaluation.

### 6.5.5 Diagnosis / Image Viewer

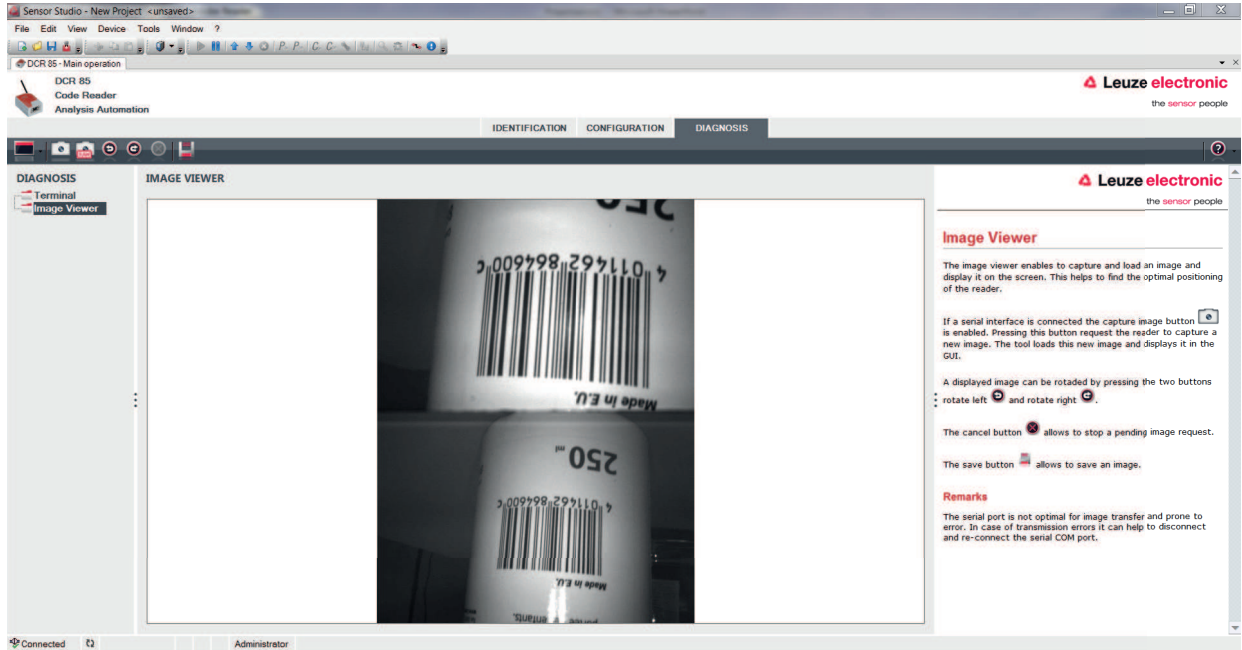



Fig. 6.8: Diagnosis / Image Viewer

You can use the Image Viewer to display the image captured in the reading field on the screen. This helps you find the optimum position for reliable reading.

If both reading fields are activated (**Decode Area Both Fields**), the high-resolution reading field and the far-range reading field are displayed in the GUI.

## 7 Starting up the device - Configuration

### 7.1 Measures to be performed prior to the initial commissioning

NOTICE	
	<ul style="list-style-type: none"><li>↳ Please observe the notices for device arrangement, see chapter 4.1 "Selecting a mounting location".</li><li>↳ If possible, always trigger the scanner with the aid of commands or an external signal transmitter (photoelectric sensor).</li><li>↳ Before commissioning, familiarize yourself with the operation and configuration of the device(s).</li><li>↳ Before connecting the supply voltage, recheck all connections and ensure that they have been properly made.</li></ul>

### 7.2 Starting the device

#### 7.2.1 Interface

Proper function of the interface can be most easily tested in service operation using the serial interface with the Sensor Studio configuration software and a notebook computer.

#### 7.2.2 Online commands

Using the online commands, important device functions can be checked, e.g. reading activation.

#### 7.2.3 Problems

If a problem occurs that cannot be rectified even after checking all electrical connections and settings on the devices and on the host, contact your responsible Leuze electronic subsidiary or Leuze electronic customer service, see chapter 10 "Service and support".

### 7.3 Setting the communication parameters

You have now commissioned the device. Usually, you will have to configure it before you can use it. Using the configuration options offered in the *Sensor Studio* or by means of the device DTM, the device can be individually configured according to your application. For information on the various configuration options, see chapter 6 "Configuration and diagnostics software - Sensor Studio" or refer to the online help.

It is normally sufficient to set the code type and code length in accordance with the 1D or 2D codes that are to be read in order to be able to operate the device.

The setting of code type and code length is usually accomplished by using the *Sensor Studio* configuration software (see chapter 6 "Configuration and diagnostics software - Sensor Studio").

## 8 Online commands

### 8.1 Overview of commands and parameters

Online commands can be used to send commands directly to the device for control and configuration. For this, the device has to be connected to a computer (host) via the serial interface.

Using the online commands you can:

- query the device version.
- activate and deactivate code reading.
- perform a software reset.

#### Command syntax

<cmd-prefix><cmd-type><data-size>[<data>]<reserved><crc>	
<cmd-prefix>	<0xEE><0xEE><0xEE><0xEE>
<cmd-type>	One ASCII character
<data-size>	Byte value 0 ... 240 Number of bytes in <data>
[<data>]	Optional: command data (byte values) in range of 0 ... 255
<reserved>	One byte, always <0x00>
<crc>	Two bytes crc16 check sum

#### Answer syntax

<start-tag><packet-type>[<packet-data>]<EOT>	
<start-tag>	<0x01>X<0x1E>ap/
<packet-type>	One ASCII character
[<packet-data>]	Optional: answer data
<EOT>	One byte <EOT> (<0x04> hex.)

## 8.2 General online commands

### Software version number

Command	<cmd-prefix>I<0x00><0x00><0x03><0x3C>
Description	Requests device version information
Parameter	None
Answer	<p>&lt;start-tag&gt;iVVVVWWWWXXXXSSSSSSSSSSAOODYYYYYHHIIIIJJJKKKL-LLL &lt;TAB&gt;Z...Z&lt;EOT&gt;</p> <ul style="list-style-type: none"> <li>• i: "I" string output</li> <li>• VVVV: application firmware version number</li> <li>• WWWW: core application firmware version number</li> <li>• XXXX: reserved</li> <li>• A: current execution state: "A": core is running</li> <li>• OO: OEM identifier</li> <li>• D: display type "0": no display device</li> <li>• YYYY: reserved</li> <li>• HH: hardware version</li> <li>• IIII: hardware type identifier (value in register 21B)</li> <li>• JJJJ: boot application version</li> <li>• KKKK: operating system kernel version</li> <li>• LLLL: root file-system version</li> <li>• &lt;TAB&gt;: ASCII TAB character</li> <li>• Z...Z: OEM decoder version: null-terminated string of printable ASCII characters</li> </ul> <p>Example: i10261026none0020366861A0600000080006001600660002 -&gt; cd(14.2.0)</p>

### Software reset

Command	<cmd-prefix>Z<0x01>1<0x00><0x1C><0x04>
Description	Carries out a software reset. The device is restarted and reinitialized, leaving it in the same state as when the supply voltage is switched on.
Parameter	None
Acknowledgment	<p>&lt;start-tag&gt;d&lt;EOT&gt;</p> <p>"d": done response</p>

### Start decoding

Command	<p>&lt;cmd-prefix&gt;P&lt;0x0C&gt;(35)7FFFFFFF&lt;0x00&gt;&lt;0x57&gt;&lt;0x5F&gt;</p> <p>&lt;cmd-prefix&gt;\$&lt;0x01&gt;&lt;0x03&gt;&lt;0x00&gt;&lt;0x1F&gt;&lt;0x5C&gt;</p>
Description	<p>The command consists of two individual commands.</p> <ul style="list-style-type: none"> <li>• The first command sets the decoder duration to infinity.</li> <li>• The second command activates decoding.</li> </ul>
Parameter	None
Acknowledgment	<p>&lt;start-tag&gt;d&lt;EOT&gt;</p> <p>"d": done response (twice)</p>

**Stop decoding**

Command	<cmd-prefix>P<0x05>(35)0<0x00><0x65><0x5B>
Description	The command sets the decoder duration to zero and stops decoding.
Parameter	None
Acknowledgment	<start-tag>d<EOT> "d": done response

**Start continuous decoding**

Command	<cmd-prefix>P<0x06>(C4)03<0x00><0x01><0x75>
Description	The command activates duration decoding. The read result is continuously output until it is terminated by a command.
Parameter	None
Acknowledgment	<start-tag>d<EOT> "d": done response

**End continuous decoding**

Command	<cmd-prefix>P<0x06>(C4)FF<0x00><0x1C><0x71>
Description	The command ends duration decoding.
Parameter	None
Acknowledgment	<start-tag>d<EOT> "d": done response

**8.3 Text commands**

Text commands are activated via the following start sequence: **>PA1<CR>**

With **PA8<CR>**, the input of text commands is ended.

Example:

Tab. 8.1: Activate decoding of Interleaved 2 of 5 codes with 10 (0x0A) characters

Command	Description
>PA1<CR>	Activate text commands
P(6E)1<CR>	Activate decoding of Interleaved 2 of 5 codes
P(C9)0A<CR>	Code length: 10 (0x0A) characters
PA8<CR>	Deactivate text commands

**Command syntax**

<Command-Type><Command-Data><CR>		
<Command-Type>	P	The settings are stored in a register. The settings are lost when the device is restarted.
	C	The settings are stored in a register. The settings remain stored when the device is restarted.
<Command Data>		See tables
<CR>		Carriage return ASCII control character 0x0D

**Command data**

Format: (XXX)YYY

- XXX: register number in ASCII hex
- YYY: setting value in ASCII hex

Tab. 8.2: Decoding – Common properties

	Parameter settings	Command data
Common properties	Maximum labels to decode	(34)1 ... 10
	Ignore duplicate codes (ms)	(159)0 ... 7FFFFFFF

Tab. 8.3: Decoding – 1D codes

Code	Parameter settings	Command data
Code properties	1D barcode aggressiveness	
	Most aggressive	(13)0
	Less aggressive	(13)1
	Less aggressive	(13)2
Interleaved 2 of 5	Settings of register C9 are bitwise OR-connected. <ul style="list-style-type: none"> <li>• The length (number of digits) is always even and can be represented by an integer value without using bit 0.</li> <li>• Bit 0 is used to enable/disable Small Quiet Zone (SMZ)</li> </ul>	
Interleaved 2 of 5	Decoding	
	enable	(6E)1
	disable	(6E)0
Interleaved 2 of 5	Length	(C9)0 ... 64
Interleaved 2 of 5	Small Quiet Zone (SMZ)	
	enable	(C9)1
	disable	(C9)0
Interleaved 2 of 5	Checksum checking	
	disable	(71)0
	enable	(71)1
	Enable and strip from output	(71)2
Code 32 Code 39	Decoding	
	disable	(6B)0
	enable Code 39 but not Code 32	(6B)1
	enable Code 32 but not Code 39	(6B)2
	enable Code 39 and Code 32	(6B)3
Code 39	Checksum checking	
	disable	(70)0
	enable	(70)1
	Enable and strip from output	(70)3
Code 39	Full ASCII symbology	
	disable	(49)0
	enable	(49)1

Code	Parameter settings	Command data
Code 93	Decoding	
	disable	(6C)0
	enable	(6C)1
Code UPC Code EAN	UPC and EAN codes enabled	
	disable	(6A)0
	enable	(6A)1
Code UPC	Supplemental data output	
	disable	(4E)0
	enable	(4E)1
Code 128	Decoding	
	enable	(6D)1
	disable	(6D)0
Codabar	Decoding	
	enable	(6F)1
	disable	(6F)0
Codabar	Checksum checking	
	disable	(48)0
	enable	(48)1
	Enable and strip from output	(48)3
GS1 DataBar	The settings of register 4C are bitwise OR-connected <ul style="list-style-type: none"> <li>• Example: Command (4C)06 enables GS1 DataBar Limited decoding and GS1 DataBar Expanded Stacked decoding</li> <li>• Command (4C)00 disables all GS1 DataBar symbologies</li> </ul>	
GS1 DataBar	Omnidirectional Decoding, Truncated Decoding	
	enable	(4C)08
	disable	(4C)00
GS1 DataBar	Limited decoding	
	enable	(4C)04
	disable	(4C)00
GS1 DataBar	Expanded decoding	
	enable	(4C)01
	disable	(4C)00
GS1 DataBar	Omnidirectional Stacked Decoding, Stacked Decoding	
	enable	(4C)10
	disable	(4C)00
GS1 DataBar	Expanded tacked decoding	
	enable	(4C)02
	disable	(4C)00

Code	Parameter settings	Command data
MSI Plessey	The settings of register 4F are bitwise OR-connected <ul style="list-style-type: none"> <li>• Example: Command (4F)25 enables MSI Plessey decoding with Two Bytes Modulo 11/10 checksum and UK Plessey decoding</li> <li>• Command (4F)00 disables all MSI Plessey decoding and the checksum settings</li> </ul>	
MSI Plessey	Decoding	
	enable	(4F)01
	disable	(4F)00
MSI Plessey	Checksum method	
	Checksum checking disabled	(4F)00
	One Byte Modulo 10	(4F)02
	Two Bytes Modulo 11/10	(4F)04
	Two Bytes Modulo 10	(4F)06
	One Byte Modulo 10 and strip from output	(4F)09
	Two Bytes Modulo 11/10 and strip from output	(4F)0A
	Two Bytes Modulo 10 and strip from output	(4F)0C
MSI Plessey	UK Plessey (original) decoding	
	enable	(4F)20
	disable	(4F)00

Tab. 8.4: Decoding extras – 1D codes

Parameter settings	Command data
Settings of register 24F are bitwise OR-connected. Example: Command (24F)8435 enables the following options <ul style="list-style-type: none"> <li>• Send Code 39 start and stop delimiter</li> <li>• Force output of all decoding data to upper case</li> <li>• Remove UPC-A check digit</li> <li>• Remove UPC-A number system digit</li> <li>• Convert EAN-8 to EAN-13</li> <li>• Remove GS1 DataBar “( )” characters</li> </ul>	
Send Code 39 start and stop delimiters	
enable	(24F)0001
disable	(24F)0000
Remove Codabar start and stop delimiters	
enable	(24F)0002
disable	(24F)0000
Force all decoding data to upper case	
enable	(24F)0004
disable	(24F)0000
Force all decoding data to lower case	
enable	(24F)0008
disable	(24F)0000

Parameter settings	Command data
Remove UPC-A check digit	
enable	(24F)0010
disable	(24F)0000
Remove UPC-A number system digit	
enable	(24F)0020
disable	(24F)0000
Remove UPC-E check digit	
enable	(24F)0040
disable	(24F)0000
Remove UPC-E number system digit	
enable	(24F)0080
disable	(24F)0000
Remove EAN-13 check digit	
enable	(24F)0100
disable	(24F)0000
Remove EAN-8 check digit	
enable	(24F)0200
disable	(24F)0000
Convert EAN-8 to EAN-13	
enable	(24F)0400
disable	(24F)0000
Convert UPC-A to EAN-13	
enable	(24F)0800
disable	(24F)0000
Convert Bookland EAN-13 to ISBN	
enable	(24F)1000
disable	(24F)0000
Convert Bookland EAN-13 to ISSN	
enable	(24F)2000
disable	(24F)0000
Remove GS1 DataBar “()” characters	
enable	(24F)8000
disable	(24F)0000

Tab. 8.5: Decoding – Stacked codes

Code	Parameter settings	Command data
PDF 417	Decoding	
	enable	(29)1
	disable	(29)0
	Micro PDF 417 decoding	
	enable	(2A)1
	disable	(2A)0

Tab. 8.6: Decoding – 2D codes

Code	Parameter settings	Command data
Code properties	Image transform	
	No transform	(14)0
	Mirror	(14)1
DataMatrix	Settings of register 19 are bitwise OR-connected. Example: <ul style="list-style-type: none"> <li>• Command (19)5 enables standard and mirror DataMatrix decoding and disables inverse DataMatrix decoding.</li> </ul>	
DataMatrix	Standard decoding	
	enable	(19)1
	disable	(19)0
DataMatrix	Inverse decoding	
	enable	(19)2
	disable	(19)0
DataMatrix	Mirror decoding	
	enable	(19)4
	disable	(19)0
DataMatrix	Rectangular symbology	
	enable	(16)1
	disable	(16)0
Aztec	Settings of register 50 are bitwise OR-connected. Example: <ul style="list-style-type: none"> <li>• Command (50)5 enables standard and mirror Aztec decoding and disables inverse Aztec decoding.</li> </ul>	
Aztec	Standard decoding	
	enable	(50)1
	disable	(50)0
Aztec	Inverse decoding	
	enable	(50)2
	disable	(50)0
Aztec	Mirror decoding	
	enable	(50)4
	disable	(50)0

Code	Parameter settings	Command data
QR code	Settings of register 2B are bitwise OR-connected. Example: <ul style="list-style-type: none"> <li>Command (2B)11 enables standard and mirror QR Code decoding and disables inverse, micro, and Model 1 QR Code decoding.</li> </ul>	
QR code	Standard decoding	
	enable	(2B)01
	disable	(50)00
QR code	Inverse decoding	
	enable	(2B)02
	disable	(2B)00
QR code	Micro decoding	
	enable	(2B)04
	disable	(2B)00
QR code	Mirror decoding	
	enable	(2B)10
	disable	(2B)00
QR code	Model 1 decoding	
	enable	(2B)20
	disable	(2B)00

Tab. 8.7: Output

Parameter settings	Command data
Notification of read failure	
enable	(55)1
disable	(55)0
Output result with AIM ID	
AIM ID in prefix	(ED)1
No AIM ID in prefix	(ED)0

Tab. 8.8: Control options

Option	Parameter settings	Command data
Trigger duration		
	Trigger duration [ms]	(35)0 ... 7FFFFFFF
Decode area		
	Read in both fields	(39)3
	Read in high-density field	(39)5
	Read in wide-angle field	(39)6
Continuous action		
	idle	(C4)FF
	Read continuously in both fields	(C4)03
	Read continuously in high-density field	(C4)05
	Read continuously in wide-angle field	(C4)06
	Motion control	(C4)F0
Illumination		
	Minimum illumination	(04)0
	Leave illumination during read	(04)1
Targeting		
	enable	(0F)1
	disable	(0F)0
	Target time before decoding [ms]	(33)0 ... 7FFFFFFF
Beep volume		
	silent	(26)00
	low	(26)21
	medium	(26)32
	high	(26)42
	full	(26)64

Tab. 8.9: Host interface settings

Setting	Parameter settings	Command data
RS 232	Baud rate [BAUD]	
	9600	(1C)02580
	19200	(1C)04B00
	38400	(1C)09600
	57600	(1C)0E100
	115200	(1C)1C200
RS 232	Data length	
	7 bits	(1E)7
	8 bits	(1E)8
RS 232	Parity	
	none	(22)0
	odd	(22)1
	even	(22)2
RS 232	Stop bits	
	1 bit	(1D)1
	2 bits	(1D)2
RS 232	Flow control	
	Disabled	(1F)0
	Hardware	(1F)1
Handshake	Acknowledgment expected	
	enable	(42)1
	disable	(42)0
	Acknowledgment time limit [ms]	(37)0 ... 7FFFFFFF

## 9 Care, maintenance and disposal

Usually, the device does not require any maintenance by the operator.

### 9.1 Cleaning

Clean the glass window of the device with a soft cloth before mounting.

#### **NOTICE**



#### **Do not use aggressive cleaning agents!**

↪ Do not use aggressive cleaning agents such as thinner or acetone for cleaning the device.

### 9.2 Servicing

Repairs to the device must only be carried out by the manufacturer.

↪ For repairs, contact your responsible Leuze electronic subsidiary or Leuze electronic customer service (see chapter 10 "Service and support").

### 9.3 Disposing

↪ For disposal observe the applicable national regulations regarding electronic components.

## 10 Service and support

24-hour on-call service at:  
+49 (0) 7021 573-0

Service hotline:  
+49 (0) 7021 573-123  
Monday to Friday 8.00 a.m. to 5.00 p.m. (UTC+1)

E-mail:  
service.identify@leuze.de

Return address for repairs:  
Service center  
Leuze electronic GmbH + Co. KG  
In der Braike 1  
D-73277 Owen / Germany

### 10.1 What to do should servicing be required?

<b>NOTICE</b>	
	<p><b>Please use this chapter as a master copy should servicing be required!</b></p> <p>↳ Enter the contact information and fax the form together with your service order to the fax number given below.</p>

**Customer data (please complete)**

Device type:	
Serial number:	
Firmware:	
Display messages:	
Status of LEDs:	
Error description:	
Company:	
Contact person/department:	
Phone (direct dial):	
Fax:	
Street/No:	
ZIP code/City:	
Country:	

**Leuze Service fax number:**  
+49 (0) 7021 573-199

## 11 Technical data

### 11.1 General specifications

Tab. 11.1: Optics

Optical system	CMOS Imager, Rolling Shutter (1280 x 960)
Optical resolution	High-resolution reading field 960 x 640 Wide-range reading field 960 x 640
Reading area	20 mm ... 300 mm
Contrast	1D code: 25 % 2D code: 35 %
Resolution	1D code: $m = 0.076$ mm (3 mil), distance dependent 2D code: $m = 0.127$ mm (5 mil), distance dependent
Light sources <ul style="list-style-type: none"> <li>• Illumination</li> <li>• Alignment LEDs (Aimer)</li> </ul>	integrated LEDs <ul style="list-style-type: none"> <li>• visible red light</li> <li>• visible blue light</li> </ul>

Tab. 11.2: Code specifications

Code type: 1D	Codabar, Code 11, Code 32 , Code 39, Code 93, Code 128, Interleaved 2 of 5, GS1 DataBar (RSS), MSI Plessey, Pharmacode, UPC/EAN, 2 of 5 (IATA, Matrix, Hong Kong, Straight, NEC), Telepen
Code type: Stacked 1D	PDF417, MicroPDF, GS1 Composite, Codablock F
Code type: 2D	Data Matrix, Aztec Code, QR Code, Micro QR, MaxiCode
Postal Codes	Australian Post, Intelligent Mail, Japan Post, KIX Code, Korea Post, Planet, Postnet, UK Royal Mail, UPU ID Tags

Tab. 11.3: Interfaces

Interface type	RS 232
Baud rate	9600 ... 115200 baud, configurable
Data formats	configurable
Trigger	<ul style="list-style-type: none"> <li>• Switching input                             <ul style="list-style-type: none"> <li>• active: 0 V</li> <li>• inactive: +5 V or not connected</li> </ul> </li> <li>• Presentation Mode (Motion Control)</li> </ul>
Switching output	NPN transistor output, max. 20 mA, Good Read

Tab. 11.4: Electrical equipment

Operating voltage	4.5 ... 5.5 V DC
Current consumption	Duration reading: typ. 350 mA Inactive illumination: typ. 75 mA
LEDs	1 device status 1 read status

Tab. 11.5: Mechanical data

Degree of protection	IP 54
Connection type	fixed cable, 2 m long, 6 x 0.081 mm <sup>2</sup> (AWG 28)
Weight	70 g (without cable)
Dimensions (H x W x D)	25 x 39 x 55.5 mm
Fastening	3x M2.5 bore holes, 5 mm deep
Housing	Metal, die-cast aluminum

Tab. 11.6: Environmental data

Ambient temp. (operation/storage)	0 °C ... +50 °C/-20 °C ... +60 °C
Air humidity	10 % ... 90 % rel. humidity, non-condensing
Electromagnetic compatibility	EN 55022:2006 Class B IEC 62471:2006
Conformity	CE, FCC
Ambient light	max. 100000 Lux

## 11.2 Reading fields

### **NOTICE**



Please note that the actual reading fields are also influenced by factors such as labeling material, printing quality, scanning angle, printing contrast etc., and may thus deviate from the reading fields specified here. The origin of the read distance always refers to the front edge of the housing of the beam exit.

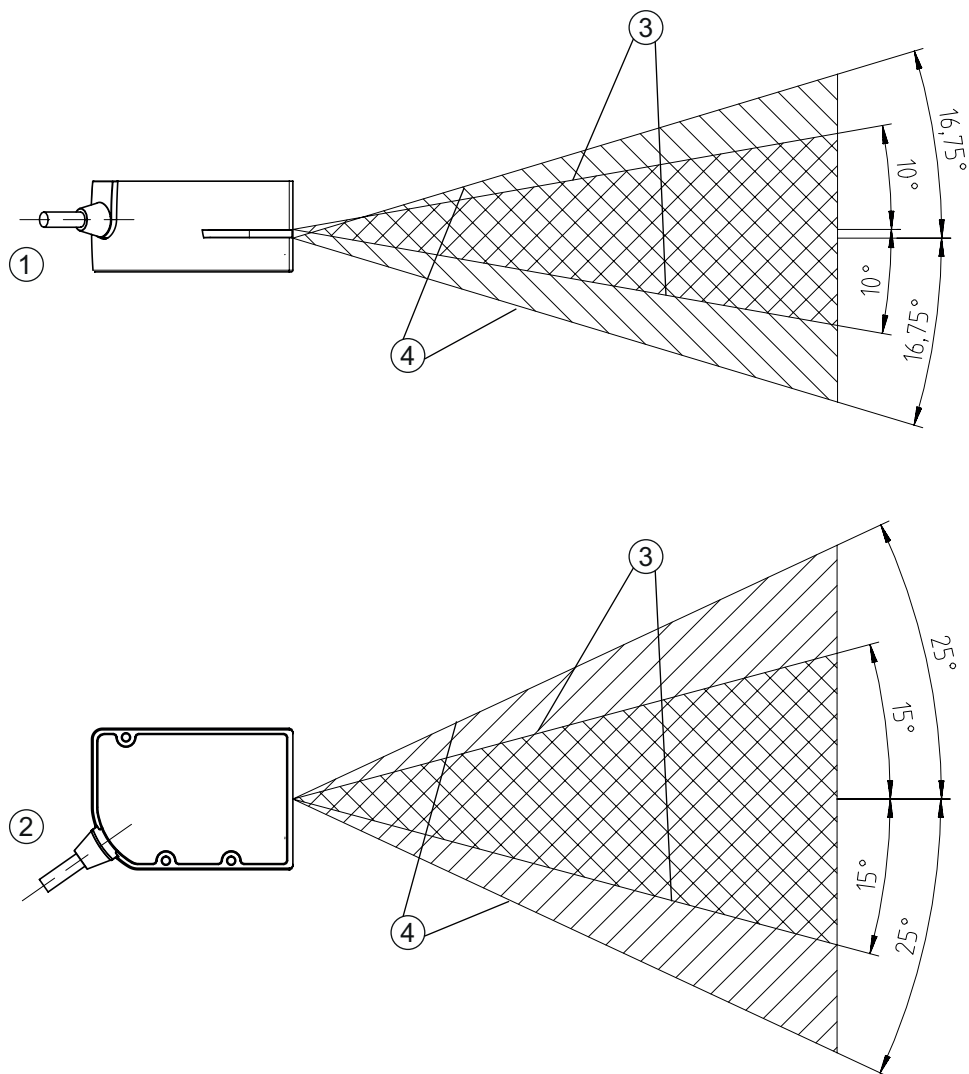

- 1 Reading fields – side view
- 2 Reading fields – top view
- 3 High resolution reading field
- 4 Wide-range reading field

Fig. 11.1: Reading fields

Tab. 11.7: Reading fields

Code type	Resolution	Typical reading distance [mm]
Code 39	0.076 mm (3 mil)	80 <span style="background-color: #cccccc;"> </span> 102
Code 39	0.190 mm (7.5 mil)	<span style="background-color: #cccccc;"> </span> 33 <span style="background-color: #cccccc;"> </span> 182
GS1 Data bar	0.267 mm (10.5 mil)	<span style="background-color: #cccccc;"> </span> 20 <span style="background-color: #cccccc;"> </span> 220
UPC Data bar	0.330 mm (13 mil)	<span style="background-color: #cccccc;"> </span> 28 <span style="background-color: #cccccc;"> </span> 280
Data Matrix	0.127 mm (5 mil)	<span style="background-color: #cccccc;"> </span> 43 <span style="background-color: #cccccc;"> </span> 115
Data Matrix	0.160 mm (6.3 mil)	<span style="background-color: #cccccc;"> </span> 33 <span style="background-color: #cccccc;"> </span> 150
Data Matrix	0.254 mm (10 mil)	<span style="background-color: #cccccc;"> </span> 20 <span style="background-color: #cccccc;"> </span> 180
Data Matrix	0.528 mm (20.8 mil)	<span style="background-color: #cccccc;"> </span> 28 <span style="background-color: #cccccc;"> </span> 343

**11.3 Dimensioned drawings**

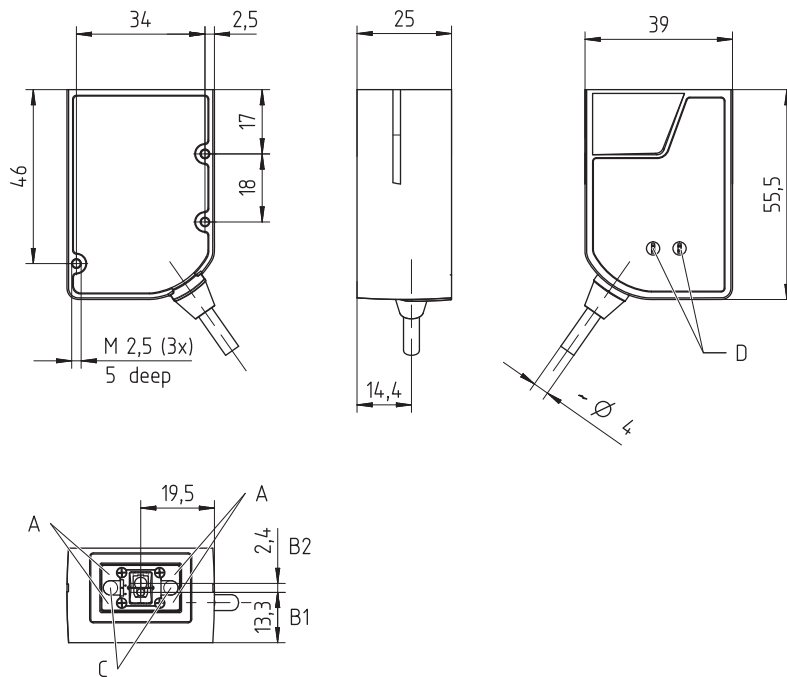

all dimensions in mm

- A 4 integrated LEDs for illumination (red light)
- B1 High resolution reading field lens
- B2 Wide-range reading field lens
- C 2 integrated target LEDs (blue light)
- D Status LEDs

Fig. 11.2: DCR 85 dimensioned drawing

## 12 Order guide and accessories

### 12.1 Type overview

Tab. 12.1: Part numbers

Part no.	Part designation	Description
50131458	DCR85M2/R2	CMOS Imager code reader for 1D- and 2D-codes, RS 232 interface, permanently attached connection cable, 2 m long
50131581	DCR85M2/R2-150-M12.8	CMOS Imager code reader for 1D- and 2D-codes, RS 232 interface, approx. 0.15 m cable with M12 connector (8-pin)

### 12.2 Accessories

Tab. 12.2: Accessories

Part no.	Part designation	Description
50128204	MA-CR	Adapter circuit board for contacting the 12-pin plug connector and conversion to SUB-D, 9-pin
50113396	KB DSub-9P-3000	RS 232 interconnection cable, cable length 3 m
50104591	K-D M12A-8P-2m-PUR	M12 connection cable, axial 8-pin socket, cable length 2 m, shielded
<i>Sensor Studio</i> configuration software Download at <a href="http://www.leuze.com">www.leuze.com</a> see chapter 6.2.1 "Downloading configuration software"		<i>Sensor Studio</i> designed according to the FDT/DTM concept. Contains: communication DTM and device DTM

**13 EC Declaration of Conformity**

The scan engines of the DCR 85 series have been developed and manufactured in accordance with the applicable European standards and directives.



## 14 Appendix

### 14.1 Bar code samples



1122334455

Module 0.3

Fig. 14.1: Code type 01: Interleaved 2 of 5



135AC

Module 0.3

Fig. 14.2: Code type 02: Code 39



a121314a

Module 0.3

Fig. 14.3: Code type 11: Codabar



abcde

Module 0.3

Fig. 14.4: Code 128



leuze

Module 0.3

Fig. 14.5: Code type 08: EAN 128



1 23456 78901 2

SC 2

Fig. 14.6: Code type 06: UPC-A



SC 3

Fig. 14.7: Code type 07: EAN 8



Fig. 14.8: Example codes

## 14.2 Configuration via configuration codes

The device can also be configured using configuration codes. The device parameters in the device are set and permanently saved after reading this code.

DCR 80 Configuration Guide			
<b>General Reading Mode Settings</b>	Continuous Scan On  M10012_02 A2	Continuous Scan Off - Default  M10011_01 A3	Motion Detection On when In Stand and Trigger Out of Stand - Default  M10403_02 A4
Motion Detection On In and Out of Stand  M10404_02 B1	Optimize Motion Detection for Bright Environments - Default  M10014_03 B2	Optimize Motion Detection for Dark Environments  M10015_03 B3	No Motion Detection Delay - Default  M10016_03 B4
500ms Motion Detection Delay  M10017_03 C1	Motion Detection Off In and Out of Stand  M10013_02 C2	Anti-Glare On  M10352_01 C3	Anti-Glare Off - Default  M10433_01 C4
Mirroring On  M10125_01 D1	Mirroring Off - Default  M10124_02 D2	Targeting On - Default  M10153_01 D3	Targeting Off  M10154_01 D4
Cell Phone Reading Enhancement On  M10163_01 E1	Cell Phone Reading Enhancement Off - Default  M10162_01 E2	<b>Data Formatting (Prefix/Suffix) Settings</b>	Erase Prefix & Suffix Data - Default  M10135_01 E4

Fig. 14.9: DCR 80 Configuration Guide







DCR 80 Configuration Guide			
Erase Prefix Data - Default  M10126_01 <b>A1</b>	Erase Suffix Data - Default  M10130_01 <b>A2</b>	Prefix AIM ID On  M10199_01 <b>A3</b>	Prefix AIM ID Off - Default  M10198_01 <b>A4</b>
Prefix Carriage Return Line Feed (RS232 Mode Only)  M10405_01 <b>B1</b>	Prefix Comma  M10127_01 <b>B2</b>	Prefix Space  M10128_01 <b>B3</b>	Prefix Tab (RS232 Mode Only)  M10319_01 <b>B4</b>
Suffix Carriage Return (RS232 Mode Only)  M10320_01 <b>C1</b>	Suffix Carriage Return Line Feed (RS232 Mode Only)  M10322_01 <b>C2</b>	Suffix Comma  M10131_01 <b>C3</b>	Suffix Line Feed (RS232 Mode Only)  M10321_01 <b>C4</b>
Suffix Space  M10132_01 <b>D1</b>	Suffix Tab (RS232 Mode Only)  M10323_01 <b>D2</b>	Translate all Characters to Uppercase On  M10220_03 <b>D3</b>	Translate all Characters to Uppercase Off - Default  M10426_02 <b>D4</b>
Symbology Settings	Australian Post On  M10288_02 <b>E2</b>	Australian Post Off - Default  M10289_02 <b>E3</b>	Aztec On - Default  M10018_01 <b>E4</b>

Fig. 14.10: DCR 80 Configuration Guide





















DCR 80 Configuration Guide			
<p>Aztec Inverse On</p>  <p>M10020_01</p> <p>A1</p>	<p>Aztec Inverse &amp; Normal On</p>  <p>M10021_01</p> <p>A2</p>	<p>Aztec Off</p>  <p>M10019_01</p> <p>A3</p>	<p>Codabar On - Default</p>  <p>M10022_01</p> <p>A4</p>
<p>Codabar Off</p>  <p>M10023_01</p> <p>B1</p>	<p>Codablock F On</p>  <p>M10027_01</p> <p>B2</p>	<p>Codablock F Off - Default</p>  <p>M10026_01</p> <p>B3</p>	<p>Code 11 On</p>  <p>M10029_01</p> <p>B4</p>
<p>Code 11 Off - Default</p>  <p>M10028_01</p> <p>C1</p>	<p>Code 11 Checksum Stripped from Result On</p>  <p>M10031_01</p> <p>C2</p>	<p>Code 32 (Italian Pharmacode) On</p>  <p>M10239_02</p> <p>C3</p>	<p>Code 32 (Italian Pharmacode) Off - Default</p>  <p>M10238_02</p> <p>C4</p>
<p>Code 39 On - Default</p>  <p>M10033_02</p> <p>D1</p>	<p>Code 39 Off</p>  <p>M10034_02</p> <p>D2</p>	<p>Code 39 Checksum On</p>  <p>M10036_01</p> <p>D3</p>	<p>Code 39 Checksum Off - Default</p>  <p>M10035_01</p> <p>D4</p>
<p>Code 39 Checksum Stripped from Result On</p>  <p>M10037_01</p> <p>E1</p>	<p>Code 39 Extended Full ASCII On</p>  <p>M10039_01</p> <p>E2</p>	<p>Code 39 Extended Full ASCII Off - Default</p>  <p>M10038_01</p> <p>E3</p>	<p>Code 93 On - Default</p>  <p>M10042_01</p> <p>E4</p>

Fig. 14.11: DCR 80 Configuration Guide





















DCR 80 Configuration Guide			
<p>Code 93 Off</p>  <p>M10043_01</p> <p><b>A1</b></p>	<p>Code 128 On - Default</p>  <p>M10044_01</p> <p><b>A2</b></p>	<p>Code 128 Off</p>  <p>M10045_01</p> <p><b>A3</b></p>	<p>Composite On</p>  <p>M10047_01</p> <p><b>A4</b></p>
<p>Composite Off - Default</p>  <p>M10046_01</p> <p><b>B1</b></p>	<p>Data Matrix Inverse On - Default</p>  <p>M10051_03</p> <p><b>B2</b></p>	<p>Data Matrix Inverse Off</p>  <p>M10050_03</p> <p><b>B3</b></p>	<p>All GS1 DataBar On - Default</p>  <p>M10054_01</p> <p><b>B4</b></p>
<p>All GS1 DataBar Off</p>  <p>M10055_01</p> <p><b>C1</b></p>	<p>GS1 DataBar Omnidirectional and GS1 DataBar Truncated On</p>  <p>M10057_03</p> <p><b>C2</b></p>	<p>GS1 DataBar Omnidirectional and GS1 DataBar Truncated Off</p>  <p>M10355_02</p> <p><b>C3</b></p>	<p>GS1 DataBar Expanded On</p>  <p>M10059_03</p> <p><b>C4</b></p>
<p>GS1 DataBar Expanded Off</p>  <p>M10417_02</p> <p><b>D1</b></p>	<p>GS1 DataBar Expanded Stacked On</p>  <p>M10357_02</p> <p><b>D2</b></p>	<p>GS1 DataBar Expanded Stacked Off</p>  <p>M10356_02</p> <p><b>D3</b></p>	<p>GS1 DataBar Limited On</p>  <p>M10056_03</p> <p><b>D4</b></p>
<p>GS1 DataBar Limited Off</p>  <p>M10354_02</p> <p><b>E1</b></p>	<p>GS1 DataBar Stacked and GS1 DataBar Stacked Omnidirectional On</p>  <p>M10058_03</p> <p><b>E2</b></p>	<p>GS1 DataBar Stacked and GS1 DataBar Stacked Omnidirectional Off</p>  <p>M10353_03</p> <p><b>E3</b></p>	<p>Han Xin On</p>  <p>M10248_01</p> <p><b>E4</b></p>

Fig. 14.12: DCR 80 Configuration Guide





















DCR 80 Configuration Guide			
<p>Han Xin Off - Default</p>  <p>M10249_01</p> <p><b>A1</b></p>	<p>Hong Kong 2 of 5 On</p>  <p>M10079_01</p> <p><b>A2</b></p>	<p>Hong Kong 2 of 5 Off - Default</p>  <p>M10078_02</p> <p><b>A3</b></p>	<p>Int 2 of 5 On - Default</p>  <p>M10060_01</p> <p><b>A4</b></p>
<p>Int 2 of 5 Off</p>  <p>M10061_01</p> <p><b>B1</b></p>	<p>Int 2 of 5 Checksum On</p>  <p>M10235_01</p> <p><b>B2</b></p>	<p>Int 2 of 5 Checksum Off - Default</p>  <p>M10234_01</p> <p><b>B3</b></p>	<p>Int 2 of 5 Checksum Stripped from Result On</p>  <p>M10065_01</p> <p><b>B4</b></p>
<p>Japan Post On</p>  <p>M10292_02</p> <p><b>C1</b></p>	<p>Japan Post Off - Default</p>  <p>M10293_02</p> <p><b>C2</b></p>	<p>KIX (Dutch Post) Code On</p>  <p>M10290_02</p> <p><b>C3</b></p>	<p>KIX (Dutch Post) Code Off - Default</p>  <p>M10291_02</p> <p><b>C4</b></p>
<p>Korean Post On</p>  <p>M10358_01</p> <p><b>D1</b></p>	<p>Korean Post Off - Default</p>  <p>M10359_01</p> <p><b>D2</b></p>	<p>Maxicode On</p>  <p>M10067_02</p> <p><b>D3</b></p>	<p>Maxicode Off - Default</p>  <p>M10066_01</p> <p><b>D4</b></p>
<p>Matrix 2 of 5 On</p>  <p>M10069_01</p> <p><b>E1</b></p>	<p>Matrix 2 of 5 Off - Default</p>  <p>M10068_01</p> <p><b>E2</b></p>	<p>Micro PDF417 On</p>  <p>M10073_01</p> <p><b>E3</b></p>	<p>Micro PDF417 Off - Default</p>  <p>M10072_01</p> <p><b>E4</b></p>

Fig. 14.13: DCR 80 Configuration Guide





















DCR 80 Configuration Guide			
<p>MSI Plessey On</p>  <p>M10076_01</p> <p><b>A1</b></p>	<p>MSI Plessey Off - Default</p>  <p>M10077_01</p> <p><b>A2</b></p>	<p>NEC 2 of 5 On</p>  <p>M10082_01</p> <p><b>A3</b></p>	<p>NEC 2 of 5 Off - Default</p>  <p>M10083_01</p> <p><b>A4</b></p>
<p>PDF417 On - Default</p>  <p>M10070_01</p> <p><b>B1</b></p>	<p>PDF417 Off</p>  <p>M10071_01</p> <p><b>B2</b></p>	<p>Pharmacode On</p>  <p>M10275_02</p> <p><b>B3</b></p>	<p>Pharmacode Off - Default</p>  <p>M10274_03</p> <p><b>B4</b></p>
<p>Pharmacode Normal Barcode Decoding (Left to Right)</p>  <p>M10281_02</p> <p><b>C1</b></p>	<p>Pharmacode Reverse Barcode Decoding (Right to Left)</p>  <p>M10280_02</p> <p><b>C2</b></p>	<p>All QR Code On</p>  <p>M10101_02</p> <p><b>C3</b></p>	<p>All QR Code Off</p>  <p>M10351_03</p> <p><b>C4</b></p>
<p>Standard QR Code On - Default</p>  <p>M10095_04</p> <p><b>D1</b></p>	<p>Straight 2 of 5 On</p>  <p>M10241_01</p> <p><b>D2</b></p>	<p>Straight 2 of 5 Off - Default</p>  <p>M10240_01</p> <p><b>D3</b></p>	<p>Telepen On</p>  <p>M10103_01</p> <p><b>D4</b></p>
<p>Telepen Off - Default</p>  <p>M10104_01</p> <p><b>E1</b></p>	<p>Trioptic On</p>  <p>M10041_01</p> <p><b>E2</b></p>	<p>Trioptic Off - Default</p>  <p>M10040_01</p> <p><b>E3</b></p>	<p>UK Plessey On</p>  <p>M10237_02</p> <p><b>E4</b></p>

Fig. 14.14: DCR 80 Configuration Guide

DCR 80 Configuration Guide			
UK Plessey Off - Default   M10236_02  <b>A1</b>	UK Royal Mail On   M10294_02  <b>A2</b>	UK Royal Mail Off - Default   M10295_02  <b>A3</b>	UPC On - Default   M10105_01  <b>A4</b>
UPC Off   M10106_01  <b>B1</b>	UPC E Expansion On   M10108_01  <b>B2</b>	UPC E Expansion Off - Default   M10107_01  <b>B3</b>	UPC Supplemental On   M10110_01  <b>B4</b>
UPC Supplemental Off - Default   M10109_01  <b>C1</b>	UPU ID-Tag On   M10360_02  <b>C2</b>	UPU ID-Tag Off - Default   M10361_02  <b>C3</b>	USPS Intelligent Mail/IMB/ 4-State CB On   M10286_02  <b>C4</b>
USPS Intelligent Mail/IMB/ 4-State CB Off - Default   M10287_02  <b>D1</b>	USPS Planet On   M10284_02  <b>D2</b>	USPS Postnet Off - Default   M10283_02  <b>D3</b>	USPS Planet Off - Default   M10285_02  <b>D4</b>
USPS Postnet On   M10282_02  <b>E1</b>	<b>RS232 Settings</b>	Reset to RS232 Factory Defaults   M10389_03  <b>E3</b>	RS232 Interface 1200 Baud Rate   M10392_01  <b>E4</b>

Fig. 14.15: DCR 80 Configuration Guide

DCR 80 Configuration Guide			
RS232 Interface 2400 Baud Rate  M10393_01 <b>A1</b>	RS232 Interface 4800 Baud Rate  M10394_01 <b>A2</b>	RS232 Interface 9600 Baud Rate  M10395_01 <b>A3</b>	RS232 Interface 19200 Baud Rate  M10396_01 <b>A4</b>
RS232 Interface 38400 Baud Rate  M10397_01 <b>B1</b>	RS232 Interface 57600 Baud Rate  M10398_01 <b>B2</b>	RS232 Interface 115200 Baud Rate - Default  M10399_01 <b>B3</b>	RS232 Interface 7 Data Bits  M10390_01 <b>B4</b>
RS232 Interface 8 Data Bits - Default  M10391_01 <b>C1</b>	RS232 Interface Stop Bits 1 - Default  M10406_01 <b>C2</b>	RS232 Interface Stop Bits 2  M10407_01 <b>C3</b>	RS232 Interface Even Parity  M10400_01 <b>C4</b>
RS232 Interface Odd Parity  M10401_01 <b>D1</b>	RS232 Interface No Parity - Default  M10402_01 <b>D2</b>	RS232 Interface Flow Control Off - Default  M10408_01 <b>D3</b>	RS232 Interface Flow Control - Hardware  M10409_01 <b>D4</b>
RS232 Packet Mode  M10388_01 <b>E1</b>	RS232 Raw Mode - Default  M10387_01 <b>E2</b>	Reader Feedback Settings	Beep Volume 100% - Default  M10197_01 <b>E4</b>

Fig. 14.16: DCR 80 Configuration Guide

DCR 80 Configuration Guide			
Beep Volume 67%   M10196_01  <b>A1</b>	Beep Volume 33%   M10195_01  <b>A2</b>	Beep Volume 0%   M10194_01  <b>A3</b>	Intentionally Blank    <b>A4</b>
<b>Scan Delay Settings</b>	Duplicate Scan Disabled - Default   M10144_01  <b>B2</b>	1 Second Duplicate Scan Delay   M10145_01  <b>B3</b>	2 Second Duplicate Scan Delay   M10146_01  <b>B4</b>
	3 Second Duplicate Scan Delay   M10147_01  <b>C1</b>	5 Second Duplicate Scan Delay   M10148_01  <b>C2</b>	10 Second Duplicate Scan Delay   M10149_01  <b>C3</b>
1 Hour Duplicate Scan Delay   M10151_01  <b>D1</b>	1 Day Duplicate Scan Delay   M10152_01  <b>D2</b>	<b>Reader/Modem Command Settings</b>   <b>Reset, Clear and Save Reader Settings</b>	Reader ID and Firmware Version   M10157_01  <b>D4</b>
Reader Text Commands On   M10137_01  <b>E1</b>	Reader Text Commands Off - Default   M10136_01  <b>E2</b>		Clear All JavaScript Rules   M10139_01  <b>E4</b>

Fig. 14.17: DCR 80 Configuration Guide



DCR 80 Configuration Guide			
<p>Clear All Stored Data and Images</p>  <p>M10138_02</p> <p><b>A1</b></p>	<p>Save All Reader Settings - Default</p>  <p>M10159_01</p> <p><b>A2</b></p>	<p>Reboot Reader</p>  <p>M10296_01</p> <p><b>A3</b></p>	<p>Intentionally Blank</p> <p><b>A4</b></p>

Fig. 14.18: DCR 80 Configuration Guide